



**FRL1.2LT**  
**Bucket technical characteristics**

**Dimensions**

D1: 110 mm

D2: 107 mm

H: 148 mm without lid

Deviation  $\pm 1\text{mm}$

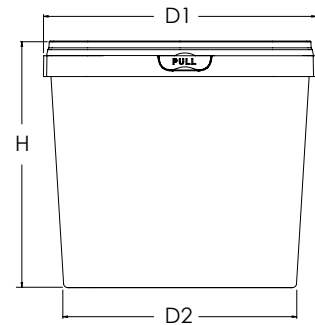

**Other elements**

Capacity (LT)

Volume to rim  
1.143 LT

Brim full volume  
1.239 LT

Net weight / Deviation ( $\pm 2.5\%$ )

72 gr

Handle

Plastic

Buckets packaging

Pallet 889 pcs

Decoration

IML Label  
339X144,80 mm

Packaging

5 Vertically

**Lid technical characteristics**

**FRL1.2LT**

**Dimensions**

D: 102 mm

H: 12.5 mm

Deviation  $\pm 1\text{mm}$

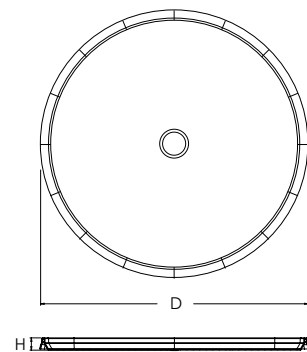

**Other elements**

Lid weight (gr)  
Deviation ( $\pm 2.5\%$ )

12 gr

Lid packaging

Carton 1.400 pcs

Decoration

IML Label  
 $\varnothing$  84 mm

**USEFUL STORAGE INFORMATION:** To preserve the quality of this product, it is recommended that it be stored in its original packaging, away from any source of local heat and moisture, away from direct sunlight (below 30°C) and dry conditions. It is recommended that the product be allowed to reach operating temperature 24 hours before use.

RAW MATERIAL: Polypropylene (PP)



ISO 22000/ISO 9001/FSSC 22000

